

IntraPack Wetcell Rack

Effective Date: 9/1/08

Bulletin Number: 803090-1

Features:

- Meets IBC - 2006 Requirements
- One of the tightest footprints available. In large battery rooms this saves enough space to allow for another string.
- Designs available for all wetcell battery makes and models.
- Rack models available include:
 - 1 tier, 2 tier, 3 tier
 - Single row, Double row
 - 2 step
 - Standard lengths 3 foot-20 foot at 1 foot increments.
 - Custom lengths to fit battery string and room requirements.
- Rack features:
 - Heavy gauge steel construction
 - Acid resistant powder coat epoxy paint
 - PVC rail covers
- Designed to use Hilti or MKT anchor bolts. Hilti M-16 or MKT equivalent recommended. Available from IntraPack.
- Optional items include:
 - Tier to tier and rack to rack output cables
 - Output terminal plates and plate covers
 - Clear polycarbonate battery terminal covers
 - Personal Safety Items: eye protection, gloves
 - Spill response kits Eye wash
 - Safety Signs Aisle Mats

For individual or battery specific drawings of the rack, please contact IntraPack.

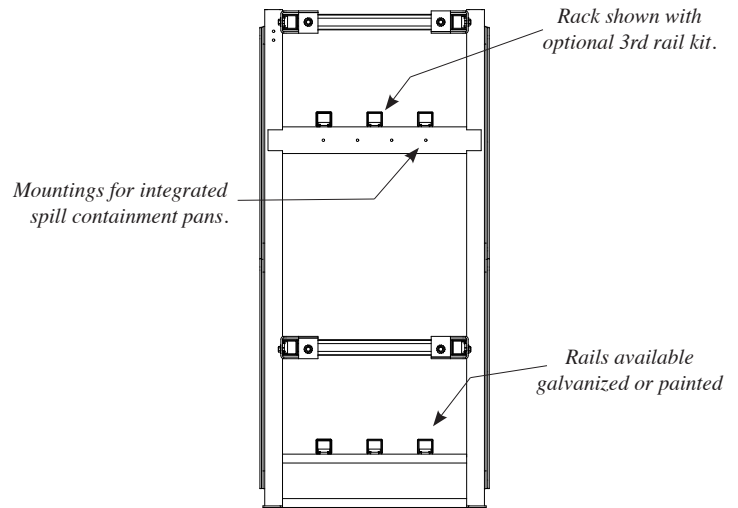

End View of 2 tier, single row rack

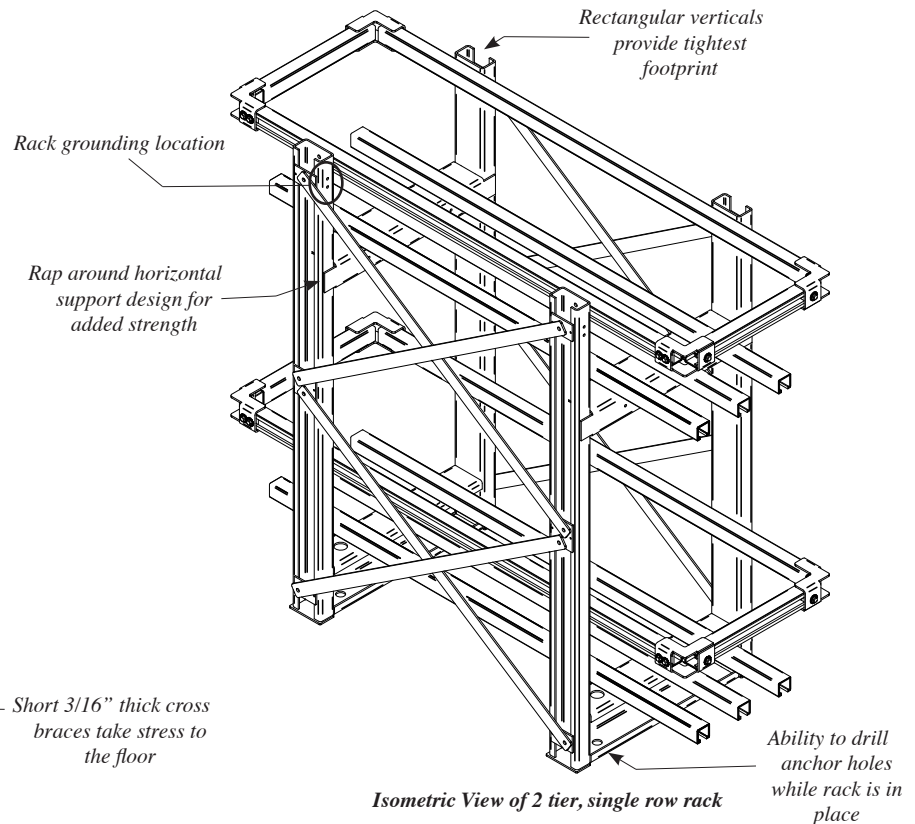

Isometric View of 2 tier, single row rack

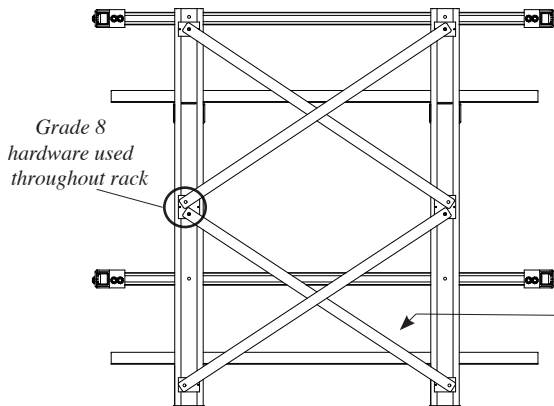

Side View of 2 tier, single row rack



Not a purchase, an investment.

10817 Sanden Drive • Dallas, Texas 75238-1338
Tel: 214-348-7105 • Fax: 214-348-7115 • Email: sales@intrapack.com